

CYLINDRICAL INSERT NUT
Large head - Open end

STEEL

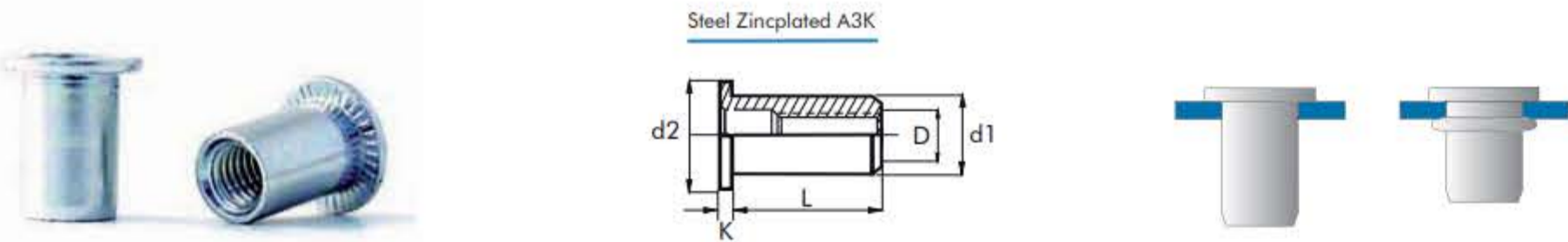

D	E MIN. mm MAX.	L Nominal mm	d1 Ø mm	d2 Ø mm	K mm	mm	PACKAGING		(N)	(N)	(Nm)	REFERENCE
							Inner	Outer				
M 4	0,5 - 2,0	9,50	5,90	9,00	1,00	6,10	500	4.000	4400	8900	4,0	0301104006
	2,0 - 4,0	12,25					500	4.000				0301114006
M 5	0,5 - 3,0	12,00	6,90	10,00	1,00	7,10	500	4.000	5300	9800	4,8	0301105007
	3,0 - 5,5	15,00					500	4.000				0301115007
	5,5 - 8,0	18,00					500	3.000				0301185007
M 6	0,5 - 3,0	14,50	8,90	13,00	1,50	9,10	250	2.000	6500	19100	12,0	0301106009
	3,0 - 5,5	16,50					250	1.500				0301116009
	5,5 - 8,0	21,50					250	1.500				0301186009
M 8	0,5 - 3,0	16,50	10,90	16,00	1,50	11,10	250	1.500	8350	29800	23,0	0301108011
	3,0 - 5,5	18,50					200	1.200				0301118011
	5,5 - 8,0	22,50					150	900				0301188011
	8,0 - 10,5	25,50					150	900				0301108011
M 10	1,0 - 3,5	17,50	11,90	16,00	1,70	12,10	150	900	12000	34000	30,0	0301101012
M 10	1,0 - 3,5	19,50	12,90	19,00	2,00	13,10	150	900	13600	39200	105,6	0301101013
	3,5 - 6,0	21,50					100	600				0301111013
	5,5 - 8,0	27,00						500				G301181013
M 12	1,0 - 4,0	25,00	15,90	23,00	2,00	16,10		500	18000	>57800	54,0	G301101216

CYLINDRICAL INSERT NUT
Reduced head - open end

STEEL

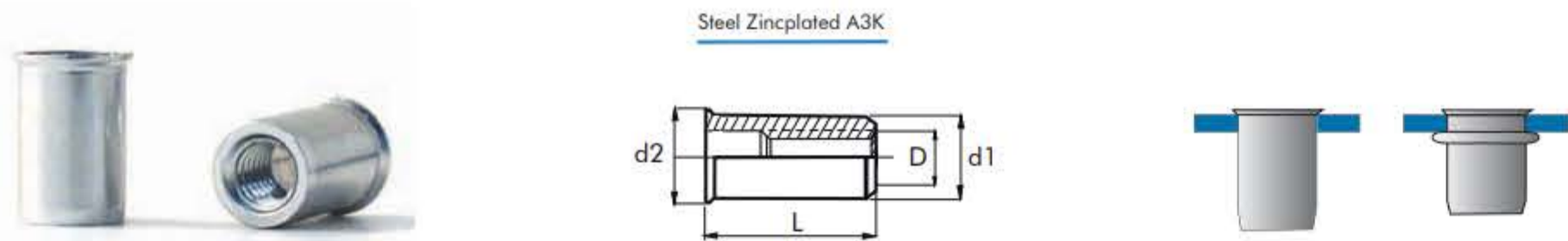

D	E MIN. mm MAX.	L Nominal mm	d1 Ø mm	d2 Ø mm	mm	PACKAGING		(N)	(N)	(Nm)	REFERENCE
						Inner	Outer				
M 3	0,5 - 2,0	8,70	4,70	5,30	4,80	1000	8.000	2100	3650	1,7	0301203005
M 4	0,5 - 2,0	10,40	6,30	6,70	6,40	500	4.000	3400	7200	1,5	0301204006
M 5	0,5 - 3,0	11,50	7,10	7,90	7,20	500	4.000	5300	9800	5,7	0301205007
M 6	0,5 - 3,0	14,50	9,50	10,60	9,60	500	3.000	6500	19100	6,5	0301206009
M 8	0,5 - 3,0	16,00	10,50	11,60	10,60	250	1.500	8350	29800	8,6	0301208011

For drills in inches.

D	E MIN. mm MAX.	L Nominal mm	d1 Ø mm	d2 Ø mm	mm	PACKAGING		(N)	(N)	(Nm)	REFERENCE
						Inner	Outer				
M 4	0,5 - 2,0	10,00	5,90	7,00	6,10	500	4.000	3400	7200	1,5	0301204005
M 5	0,5 - 3,0	12,00	6,90	8,00	7,10	500	4.000	5300	9800	5,7	0301205006
M 6	0,5 - 3,0	15,00	8,90	10,00	9,10	500	3.000	6500	19100	6,5	0301206008
M 8	0,5 - 3,0	16,00	10,90	12,00	11,10	250	1.500	8350	29800	8,6	0301208010

For drills in mm.

CYLINDRICAL INSERT NUT
Large head - closed end

STEEL

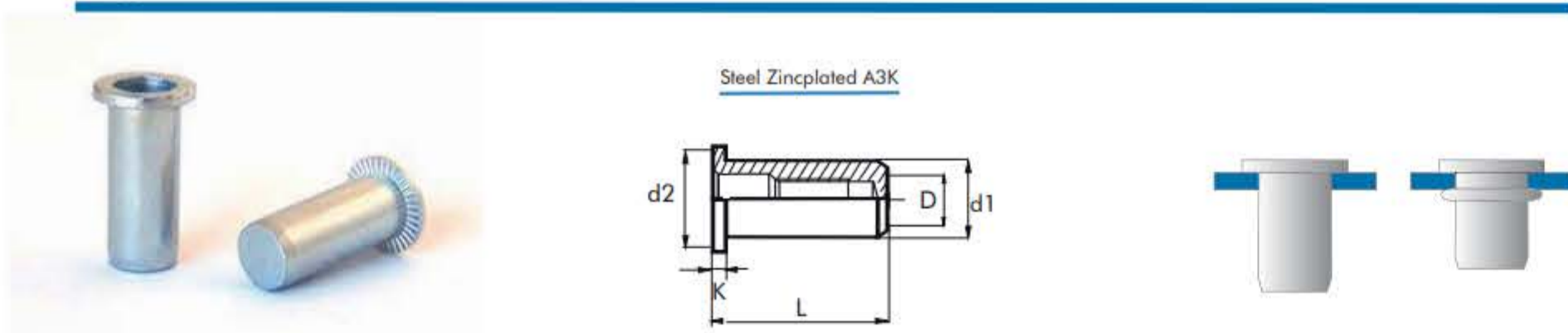

D	E MIN. mm MAX.	L Nominal mm	d1 Ø mm	d2 Ø mm	K mm	mm	PACKAGING		(N)	(N)	(Nm)	REFERENCE
							Inner	Outer				
M 5	0,5 - 2,5	18,00	6,90	10,00	1,00	7,10	500	3.000	5300	9800	7,0	0301405007
M 6	0,5 - 3,0	21,50	8,90	13,00	1,50	9,10	250	1.500	6500	19100	12,0	0301406009
M 8*	1,0 - 4,0	23,50	10,90	16,00	1,50	11,10	150	900	8300	29800	23,0	0301408011
M 10	1,0 - 4,0	31,00	12,90	19,00	2,00	13,10	50	300	13600	43300	35,1	0301401013

*Note: This insert nut has a grooved head.

