

D1 DZUS® Dart Quarter-Turn Fasteners

Studs, Glass-filled nylon

Material and Finish

Glass-filled nylon, black

Adjustment formula

Add 2.3 (.090) to panel thickness and recalculate your TMT when using self-ejecting stud assembly

To select correct fastener:

1. Select receptacle

Choose a receptacle from pages 475-477

2. Select retainer and accessories

from page 477 and note any adjustment values

3. Specify stud length

Calculate the total material thickness (TMT) using the formula given for the receptacle selected. Find the range of TMT using the stud length selection table (right) using the column (A, B, C, or D) given for the receptacle selected.

4. Complete the stud part number

by specifying the head style **H**, stud length **K**, and material **M**

Example: For rivet-on

D1-004-001-010 use column **A**
For TMT value calculated as 5.2 (.206), K = 55

For slotted head style, completed part number: D1-004-055-030
A complete example can be found on page 435.

Part Number Selection

H Head Styles - Tool Actuated

Slot Recess

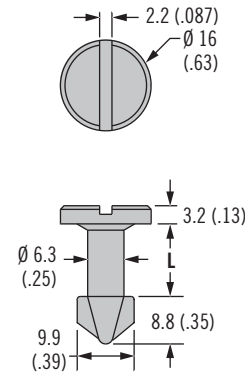

Hex Recess

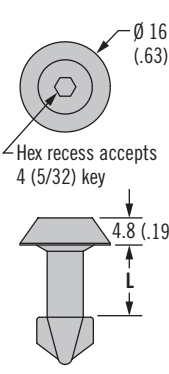

H Head Styles - Hand Actuated

Slotted Recess Knob

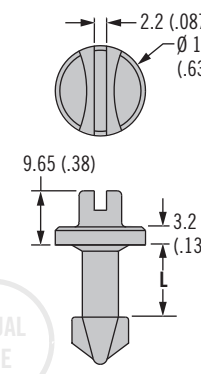

Wing

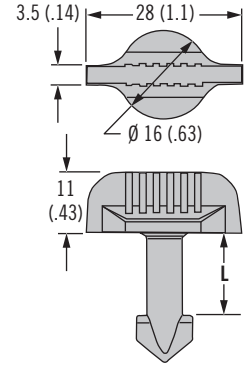

Standard Stud Assembly

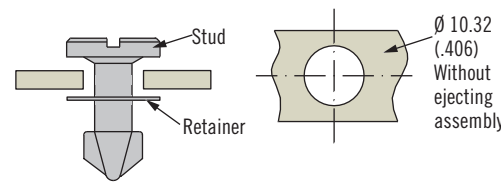

Self-Ejecting Stud Assembly

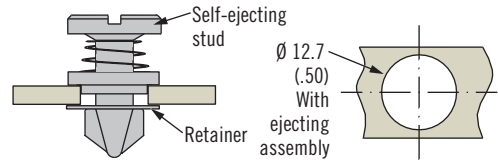

Stud Length Table									
A		B		C		D		K	L
TMT Range For: D1-004-001-010		TMT Range For: D1-004-00(F)-010		TMT Range For: D1-004-92(F)-010		TMT Range For: D1-004-91(F)-010 D1-004-01(F)-010			
Min.	Max.	Min.	Max.	Min.	Max.	Min.	Max.		
2.54 (.100)	3.80 (.149)	~	~	4.32 (.170)	5.58 (.219)	4.13 (.163)	5.39 (.212)	045	11.4 (.45)
3.81 (.150)	5.07 (.199)	3.81 (.150)	5.07 (.199)	5.59 (.220)	6.85 (.269)	5.40 (.213)	6.66 (.262)	050	12.7 (.50)
5.08 (.200)	6.34 (.249)	5.08 (.200)	6.34 (.249)	6.86 (.270)	8.12 (.319)	6.67 (.263)	7.93 (.312)	055	14.0 (.55)
6.35 (.250)	7.61 (.299)	6.35 (.250)	7.61 (.299)	8.13 (.320)	9.39 (.369)	7.94 (.313)	9.20 (.362)	060	15.2 (.60)
7.62 (.300)	8.88 (.349)	7.62 (.300)	8.88 (.349)	9.40 (.370)	10.66 (.419)	9.21 (.363)	10.47 (.412)	065	16.5 (.65)
8.89 (.350)	10.15 (.399)	8.89 (.350)	10.15 (.399)	10.67 (.420)	11.93 (.469)	10.48 (.413)	11.74 (.462)	070	17.8 (.70)
10.16 (.400)	11.42 (.449)	10.16 (.400)	11.42 (.449)	11.94 (.470)	13.20 (.519)	11.75 (.463)	13.01 (.512)	075	19.1 (.75)
11.43 (.450)	12.69 (.499)	11.43 (.450)	12.69 (.499)	13.21 (.520)	14.47 (.569)	13.02 (.513)	14.28 (.562)	080	20.3 (.80)
12.70 (.500)	13.96 (.549)	12.70 (.500)	13.96 (.549)	14.48 (.570)	15.74 (.619)	14.29 (.563)	15.55 (.612)	085	21.6 (.85)
13.97 (.550)	15.23 (.599)	13.97 (.550)	15.23 (.599)	15.75 (.620)	17.01 (.669)	15.56 (.613)	16.82 (.662)	090	22.9 (.90)
15.24 (.600)	16.50 (.649)	15.24 (.600)	16.50 (.649)	17.02 (.670)	18.28 (.719)	16.83 (.663)	18.09 (.712)	095	24.1 (.95)
16.51 (.650)	17.77 (.699)	16.51 (.650)	17.77 (.699)	18.29 (.720)	19.55 (.769)	18.10 (.713)	19.36 (.762)	100	25.4 (1.0)

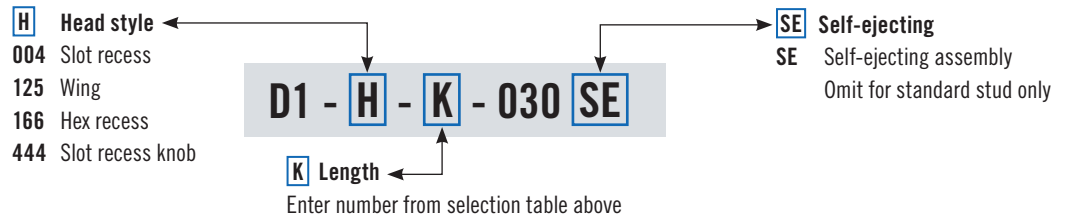

D1 DZUS® Dart Quarter-Turn Fasteners

Receptacles, Acetal

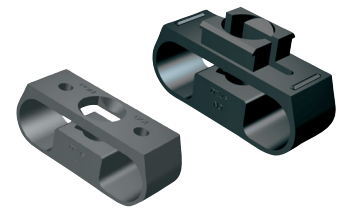

475

Rivet-On

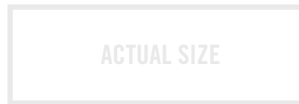
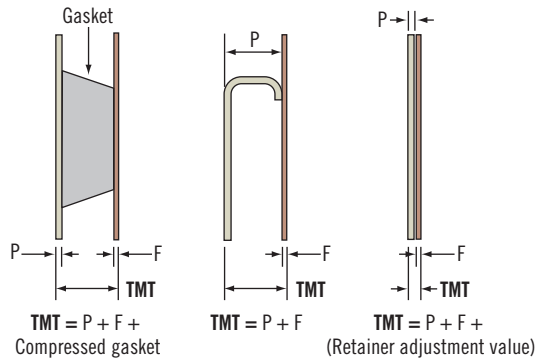
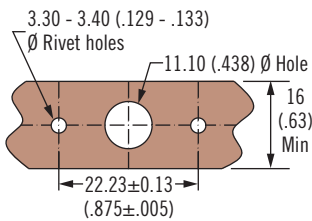
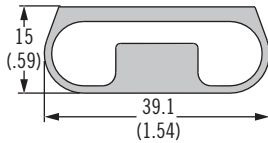
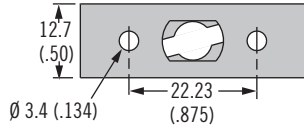

Part Number	Stud Selection Column
D1-004-001-010	A

Material and Finish

Acetal, black

Notes

After selecting receptacle use stud selection letter **A** and follow instruction on page 474

82

85

D8

D9

D1

D4

D5

D7

NY



Part Number

See table

Snap-In Back Load

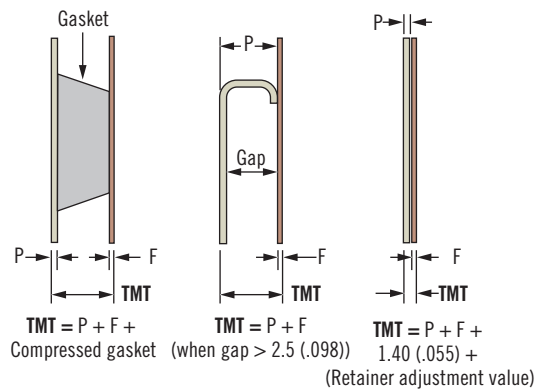
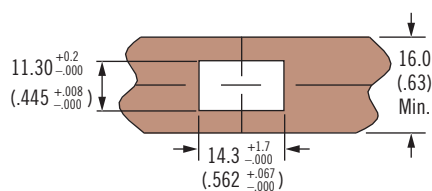
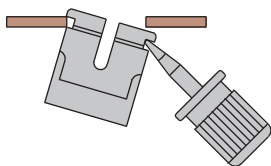
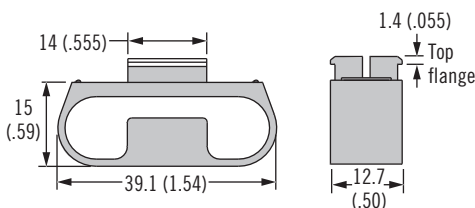

F Frame Thickness		Part Number	Stud Selection Column
Min.	Max.		
.90 (.035)	1.27 (.050)	D1-004-002-010	B
1.63 (.064)	2.00 (.080)	D1-004-003-010	
2.30 (.090)	2.64 (.104)	D1-004-004-010	
3.00 (.119)	3.40 (.135)	D1-004-005-010	
3.65 (.144)	4.00 (.158)	D1-004-006-010	

Material and Finish

Acetal black

Notes

Utilize stud selection column indicated when choosing a stud length from the stud length table on page 474

Part Number

See table



D1 DZUS® Dart Quarter-Turn Fasteners

Receptacles, Acetal

Material and Finish

Acetal, black

82

85

D8

D9

D1

D4

D5

D7

NY

Part Number

See table

Notes

Utilize stud selection column indicated when choosing a stud length from the stud length table on page 474

Mini Snap-In - Back Load

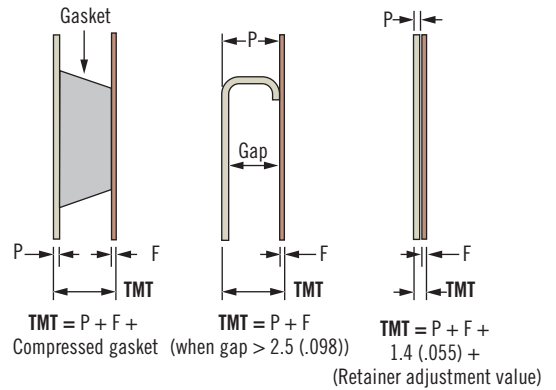
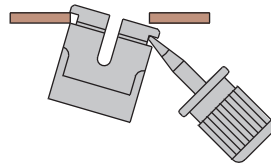
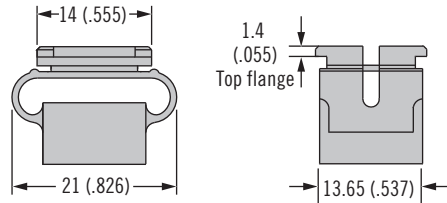

F Frame Thickness		Part Number	Stud Selection Column
Min.	Max.		
0.81 (.032)	1.27 (.050)	D1-004-012-010	D
1.29 (.051)	2.54 (.100)	D1-004-013-010	

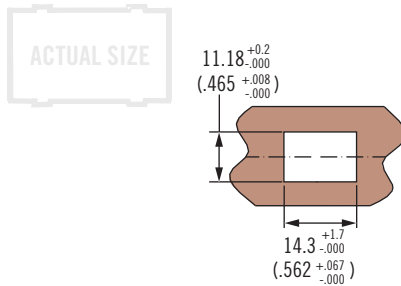

Material and Finish

Acetal, black

Mini Snap-In - Front Load

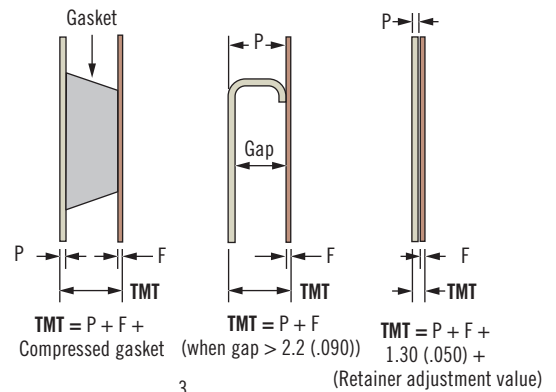
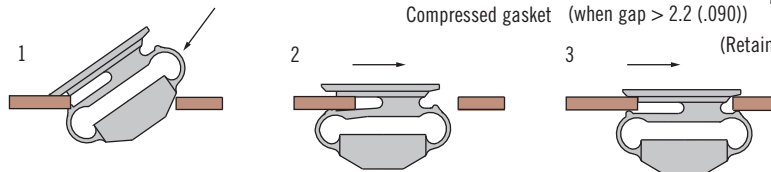
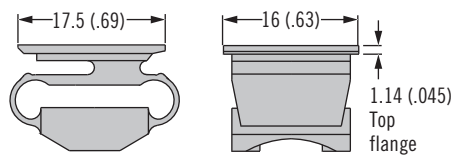

F Frame Thickness		Part Number	Stud Selection Column
Min.	Max.		
0.90 (.035)	1.25 (.049)	D1-004-911-010	D
1.30 (.051)	1.75 (.069)	D1-004-912-010	
1.80 (.071)	2.25 (.089)	D1-004-913-010	
2.30 (.091)	2.75 (.109)	D1-004-914-010	
2.80 (.111)	3.25 (.129)	D1-004-915-010	

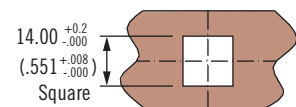

Part Number

See table

Notes

Utilize stud selection column indicated when choosing a stud length from the stud length table on page 474

D1 DZUS® Dart Quarter-Turn Fasteners

Receptacles · Retainers · Accessories

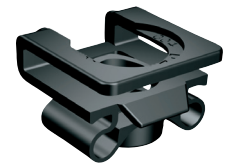

Clip-On

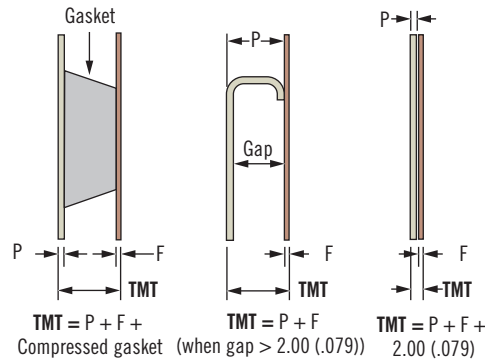
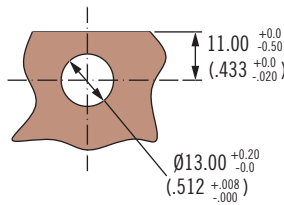
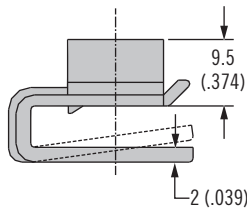
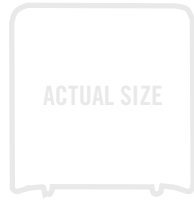
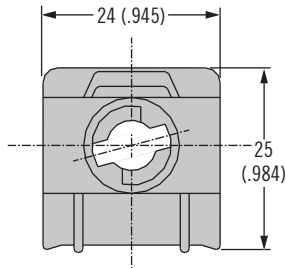

F Frame Thickness		Part Number	Stud Selection Column
Min.	Max.		
0.70 (.027)	2.30 (.090)	D1-004-921-010	C
2.30 (.090)	3.90 (.153)	D1-004-922-010	
3.9 (.153)	5.5 (.217)	D1-004-923-010	

Material and Finish

Acetal, black

Part Number

See table

Notes

Utilize stud selection column indicated when choosing a stud length from the stud length table on page 474

Retainer Split

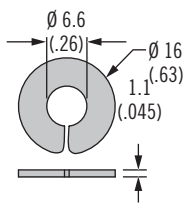

Self-Ejecting Springs

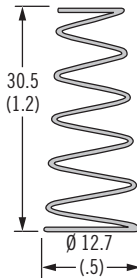
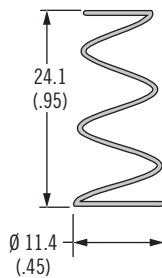

Self-Ejecting Cup

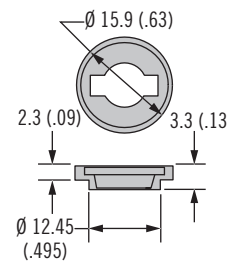

Material and Finish

See table

Part Number

See table

Notes

Adjustment value:

When using accessories the components increase TMT
Add the adjustment value to your outer panel thickness (P) when calculating TMT (see page 435 for example)

Type	K Range	Part Number	Material	Adjustment Value
Retainer split	All	D1-004-000-010	Acetal, black	Add 1.1 (.045)
Self-ejecting springs	045 to 070	D1-X1135-2S	Stainless steel	Add 2.3 (.090)
Self-ejecting springs	075 to 100	D1-X1137-2S	Stainless steel	
Self-ejecting cup	All	D1-X1129	Acetal, black	